

uStepper Δ

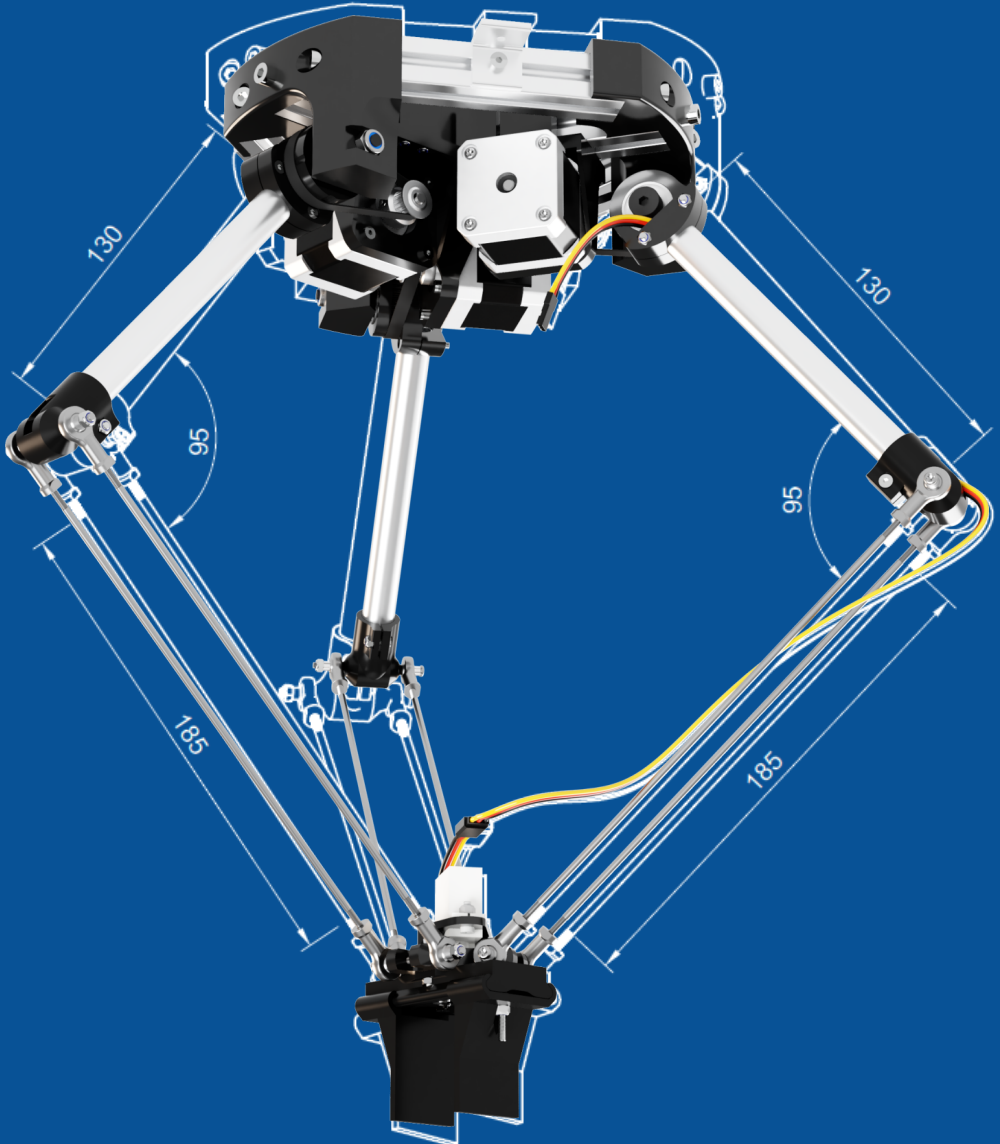

Specifications



Weight (including stepper motors)	1980 g
Material	PLA plastic and Aluminum
No. of axes	3
Maximum lift (close to base / furthest from base)	?? g / ?? g
Gear ratios (all axes)	2.5:1
Stepper motor torque	0.42 Nm
Mini servo torque	0.25 Nm @ 5 V

Bill Of Materials

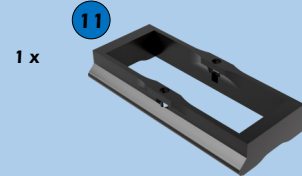
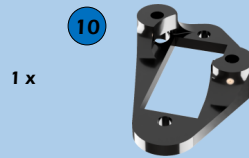
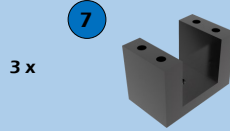
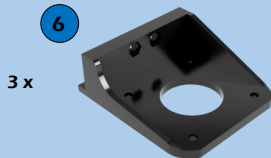
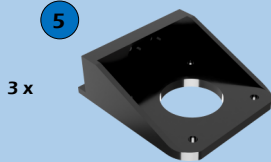
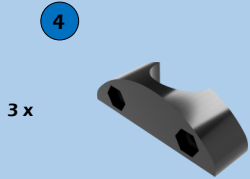
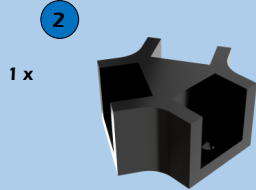
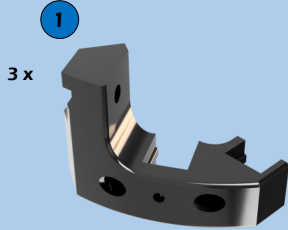

Bill Of Materials

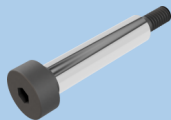

3 x shoulder bolt 7379-8-M6-35



3 x GT2 20T motor gear

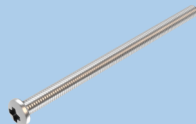

6 x M3 x 50 mm



6 x 608ZZ Bearing



3 x Belt GT2 160



9 x M4 x 8 mm

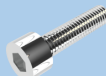

9 x M5 x 20 mm

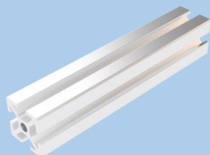

3 x 20x20 I-type 105 mm

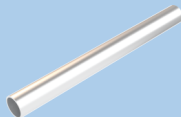

3 x Tube 15 mm x 155 mm



2 x M3 nut

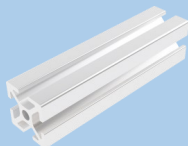

3 x 20x20 I-type 80 mm

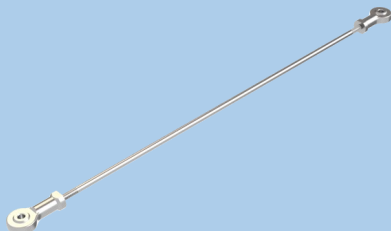

6 x Rod M3 245 mm hole to hole



31 x M3 SL nut



3 x M6 SL nut



3 x Alu angle



17 x M3 x 10 mm



3 x M8 washer



9 x T-nut M4

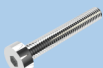

12 x M3 x 20 mm



12 x M3 x 3 mm spacer

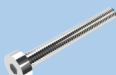

12 x M3 x 25 mm

Bill Of Materials

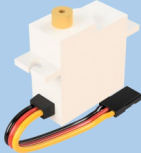

1 x HK15148B Digital MG Servo



1 x 60 cm Servo Cable



1 x 25T x 20 mm Servo Horn Set

1:1 Nuts & Bolts

M3 x 6 mm



M3 x 10 mm



M3 x 20 mm



M3 x 25 mm



M3 x 50 mm

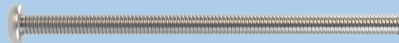

M4 x 8 mm



M5 x 20 mm

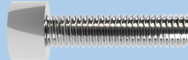

M6 x 35 mm

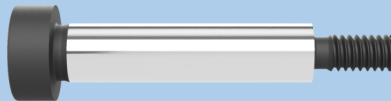

M3 nut



M6 nut



Delta Robot Assembly

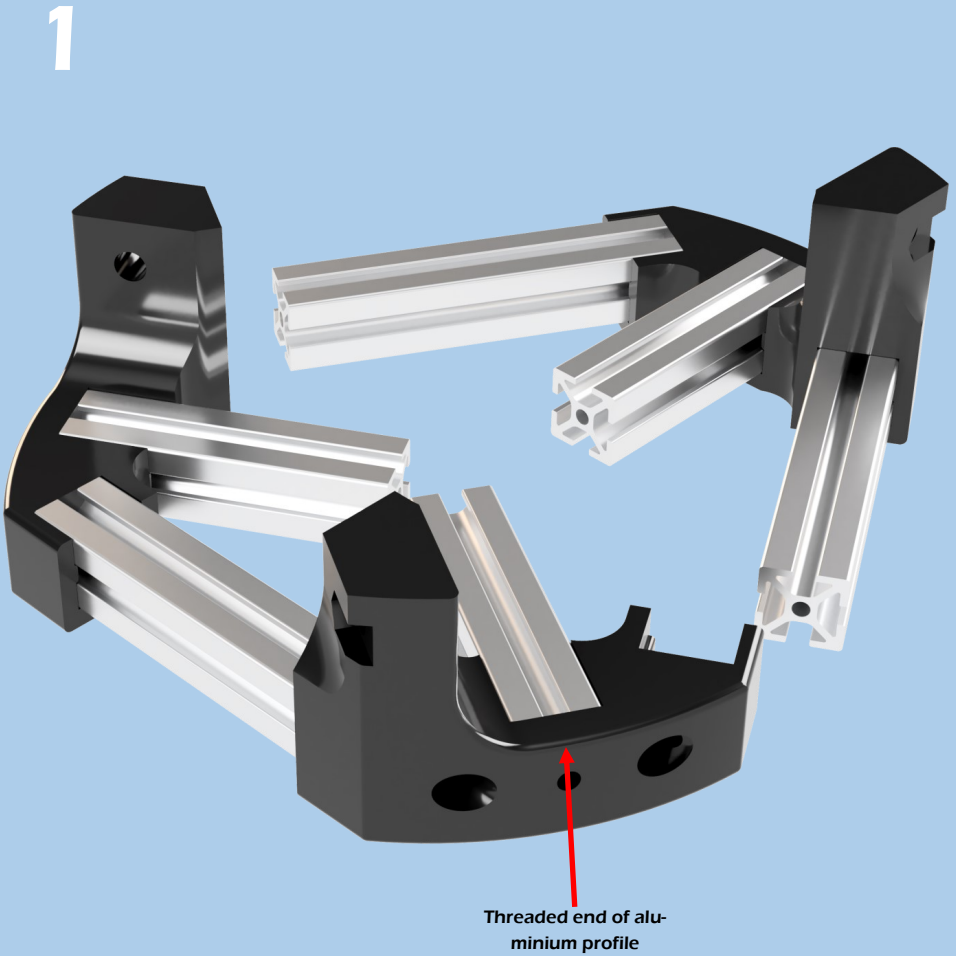
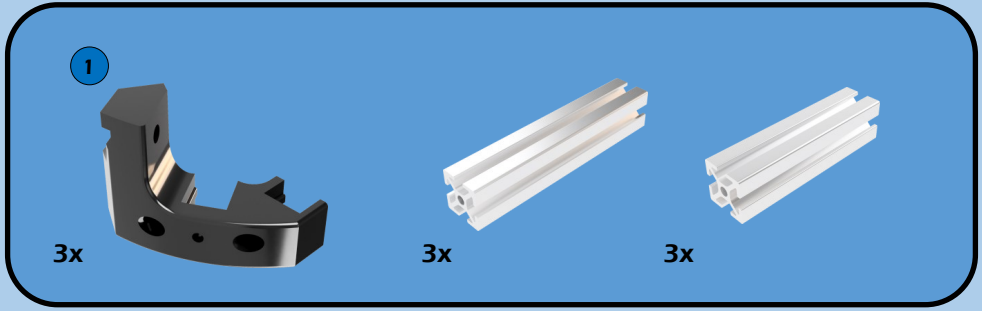

M5x20

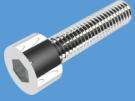

9x

2

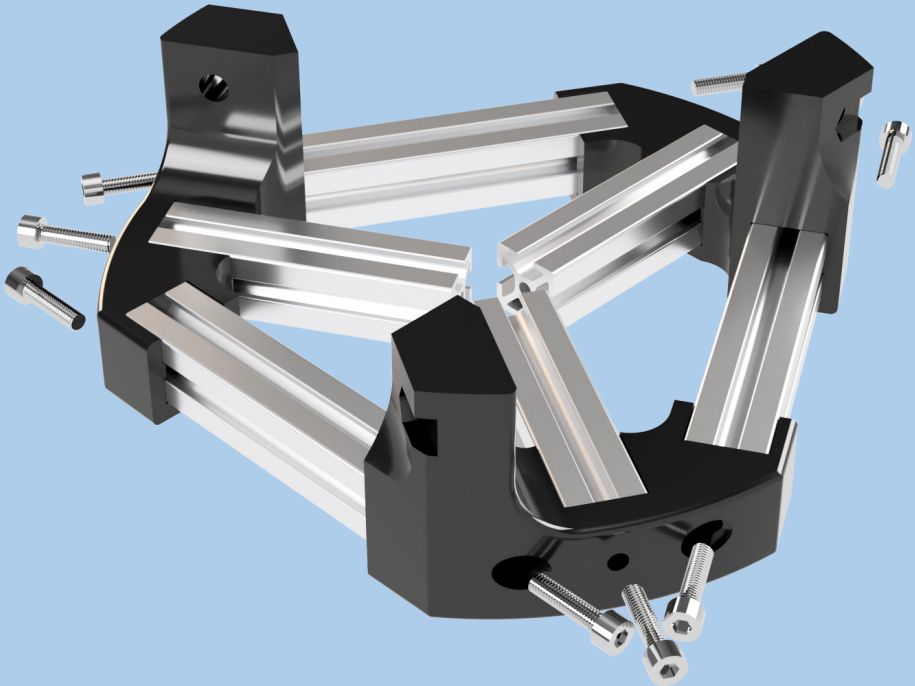

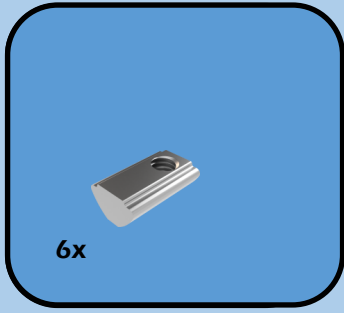

3

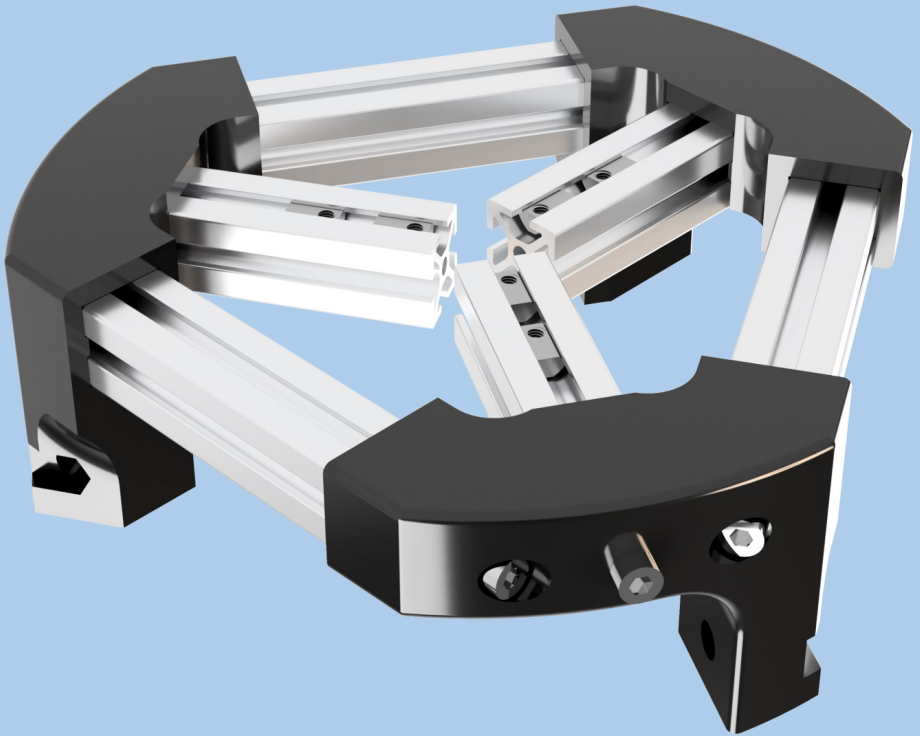

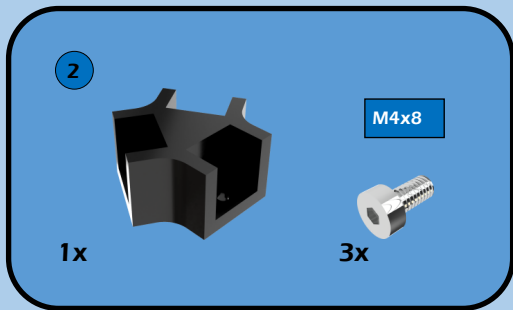

4

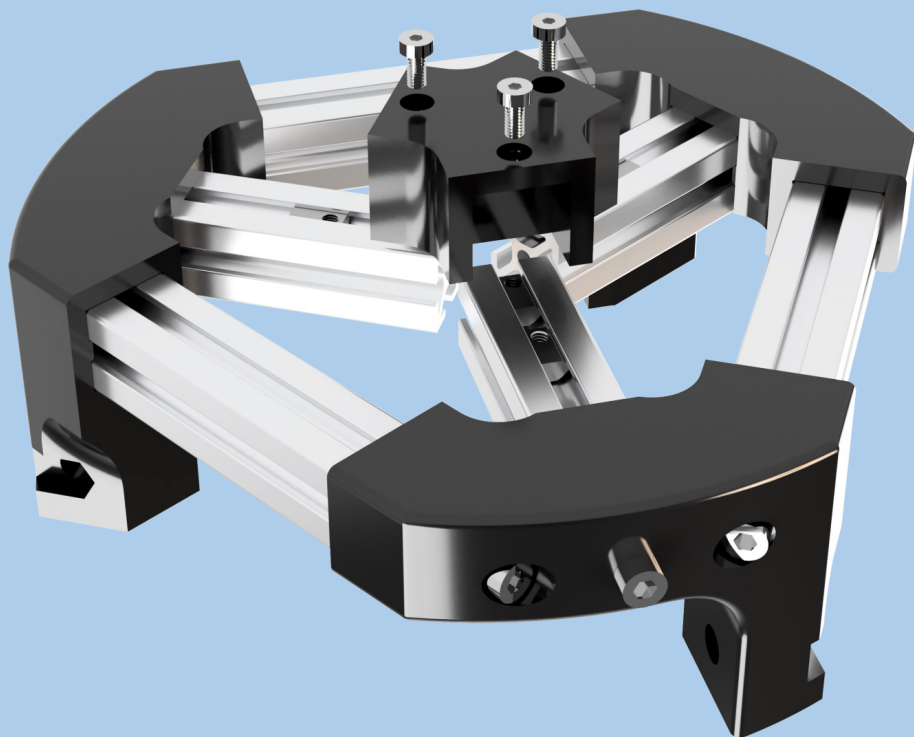

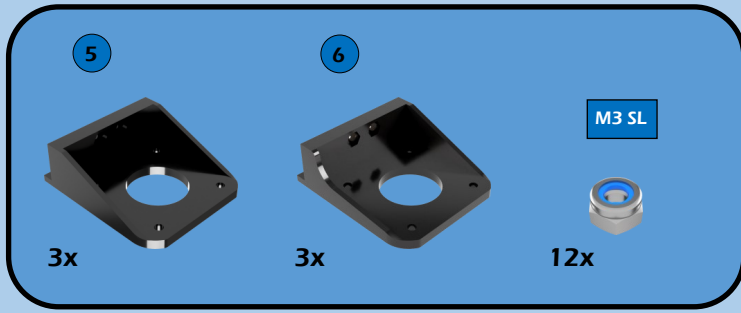

5

3 x

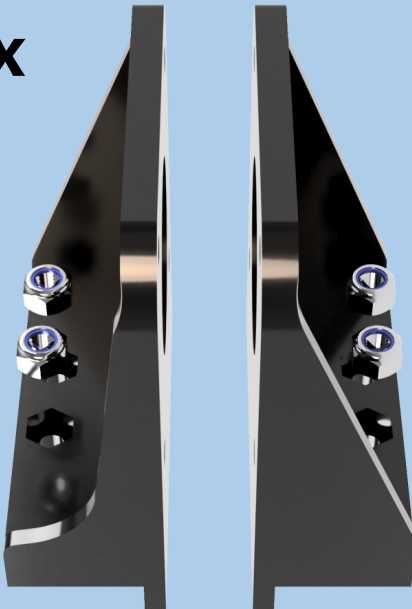

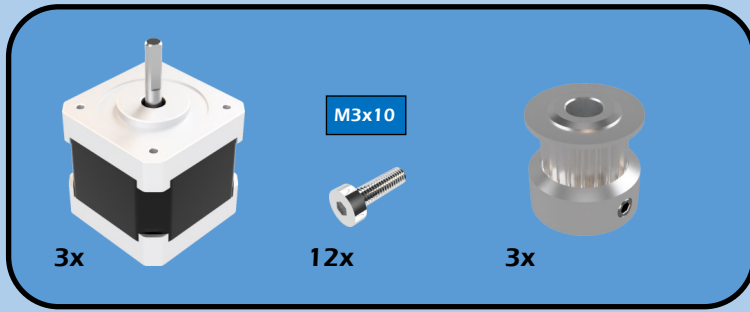

6

3 x

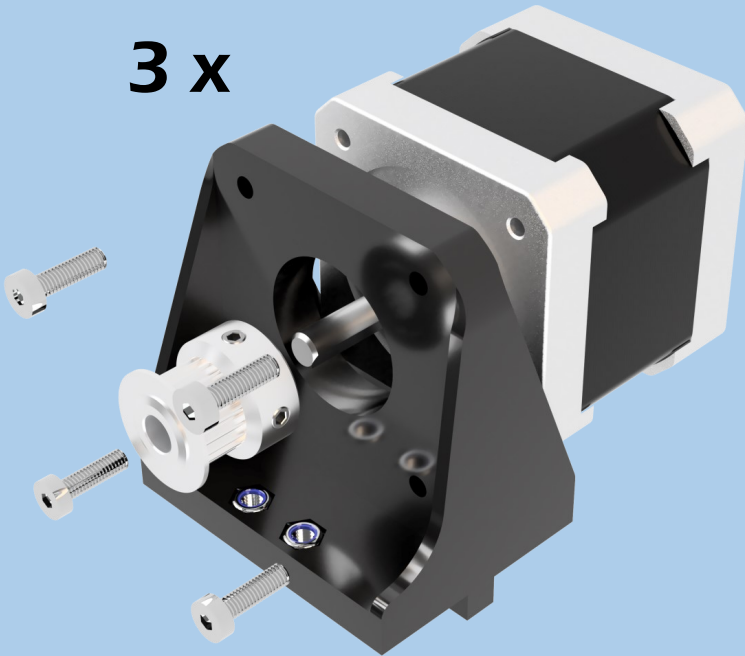

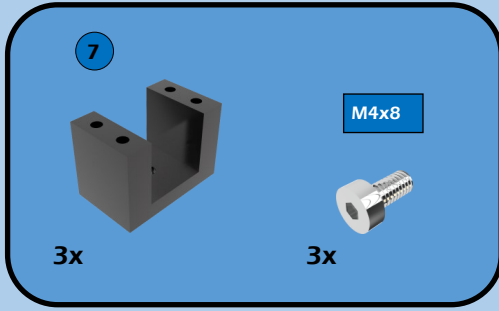

7 Do not tighten yet !

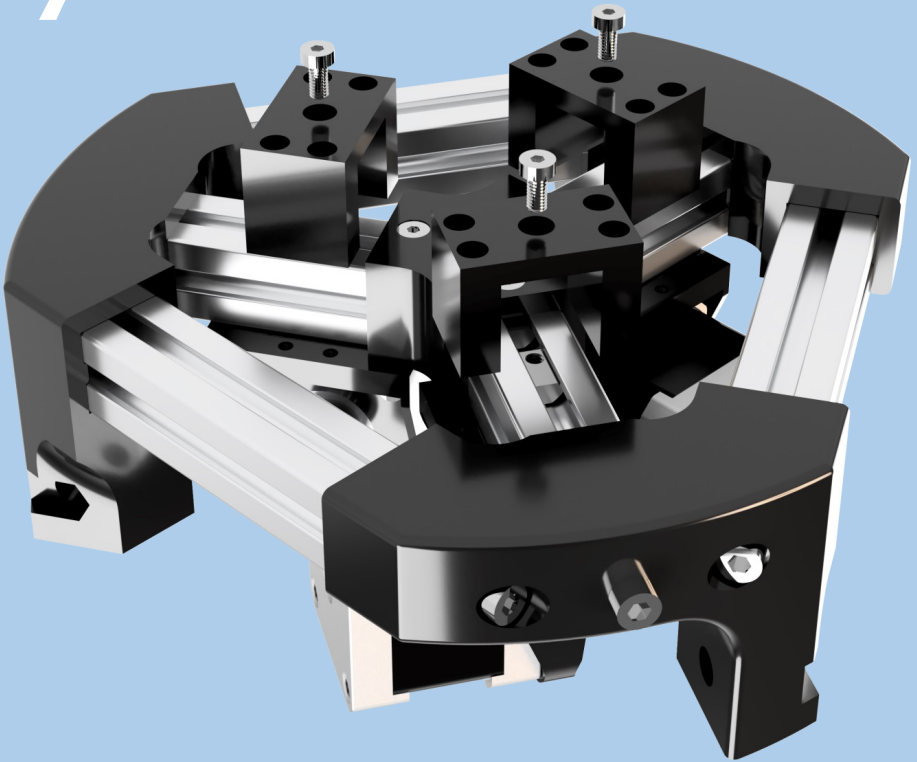

M3x25

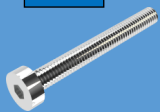

12x

8

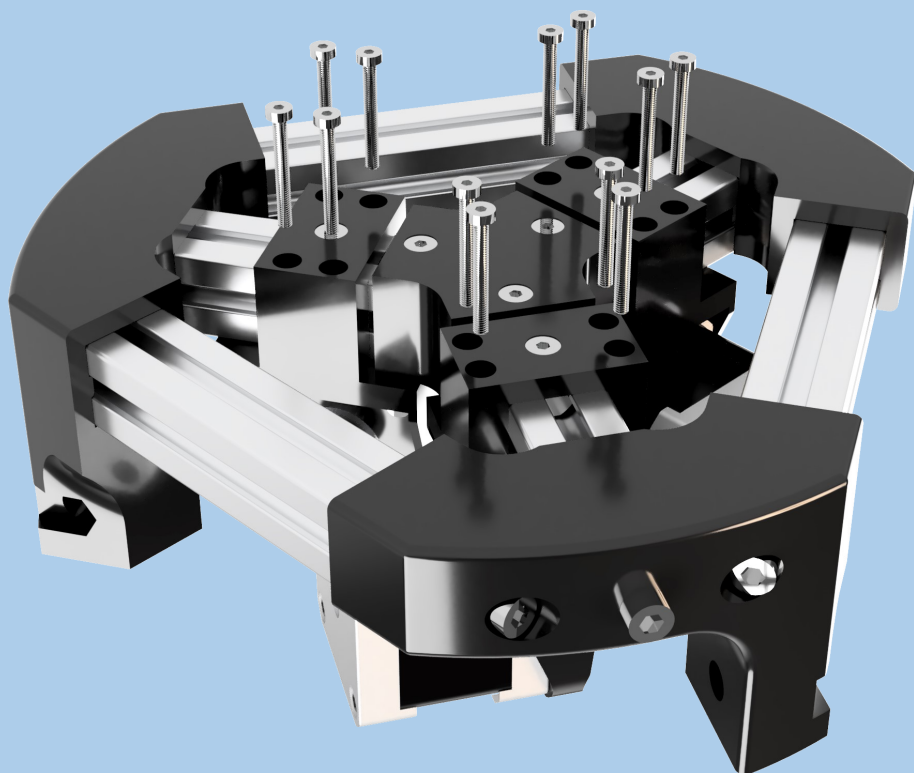

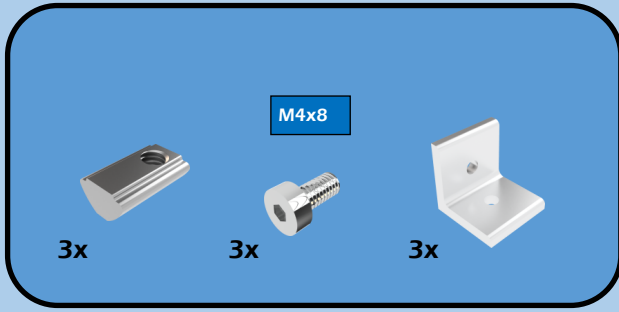

9

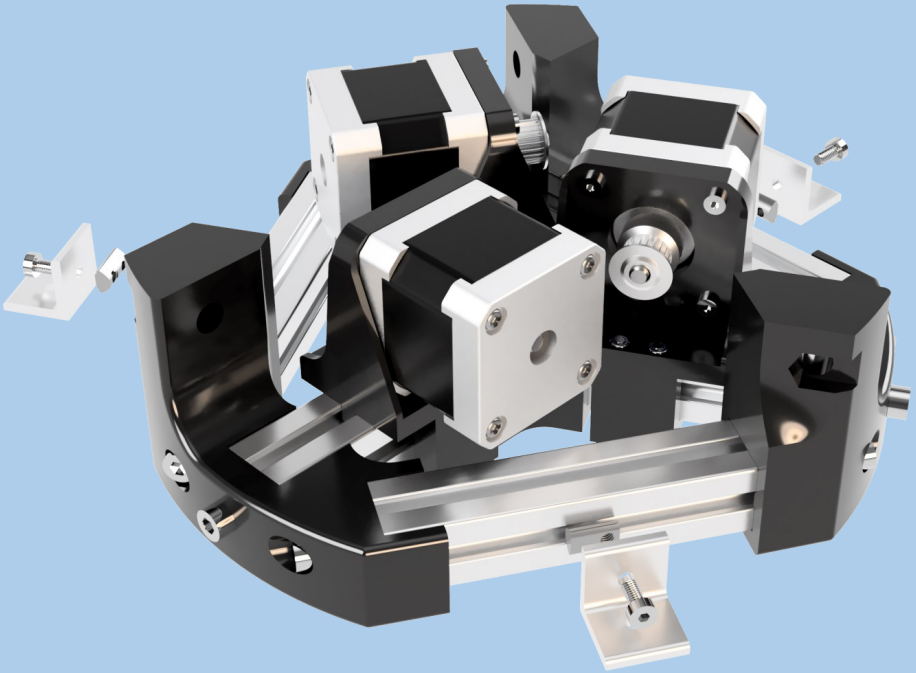

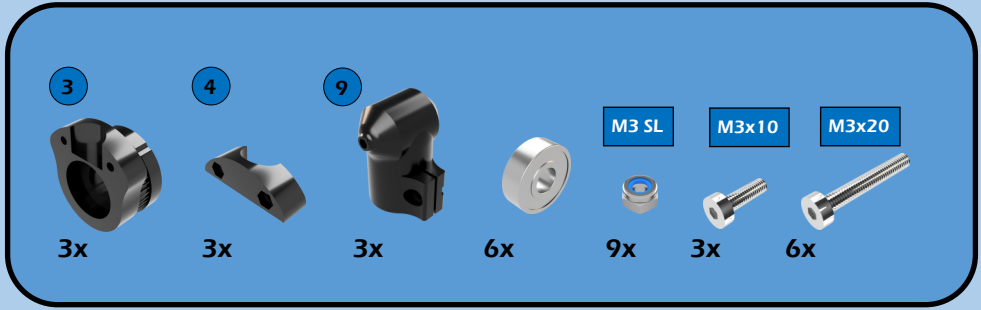

10

3 x



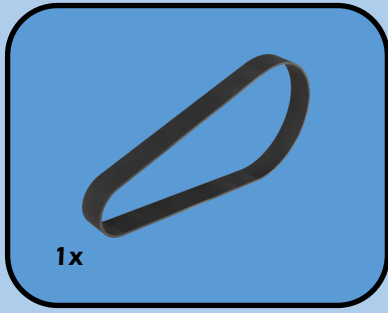

11

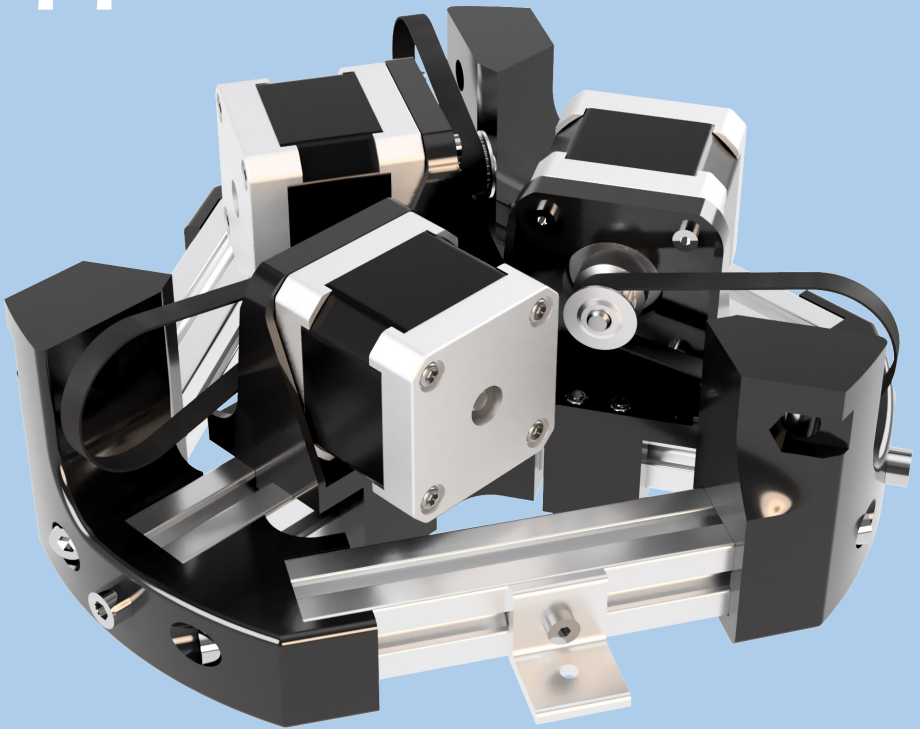

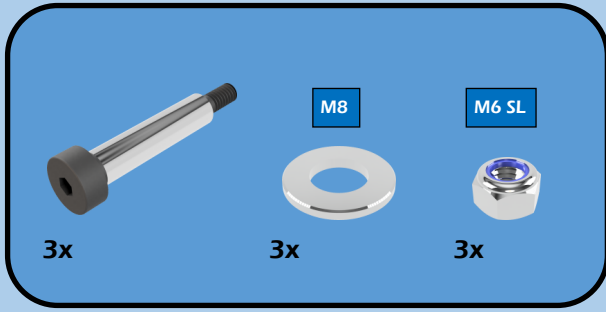

12

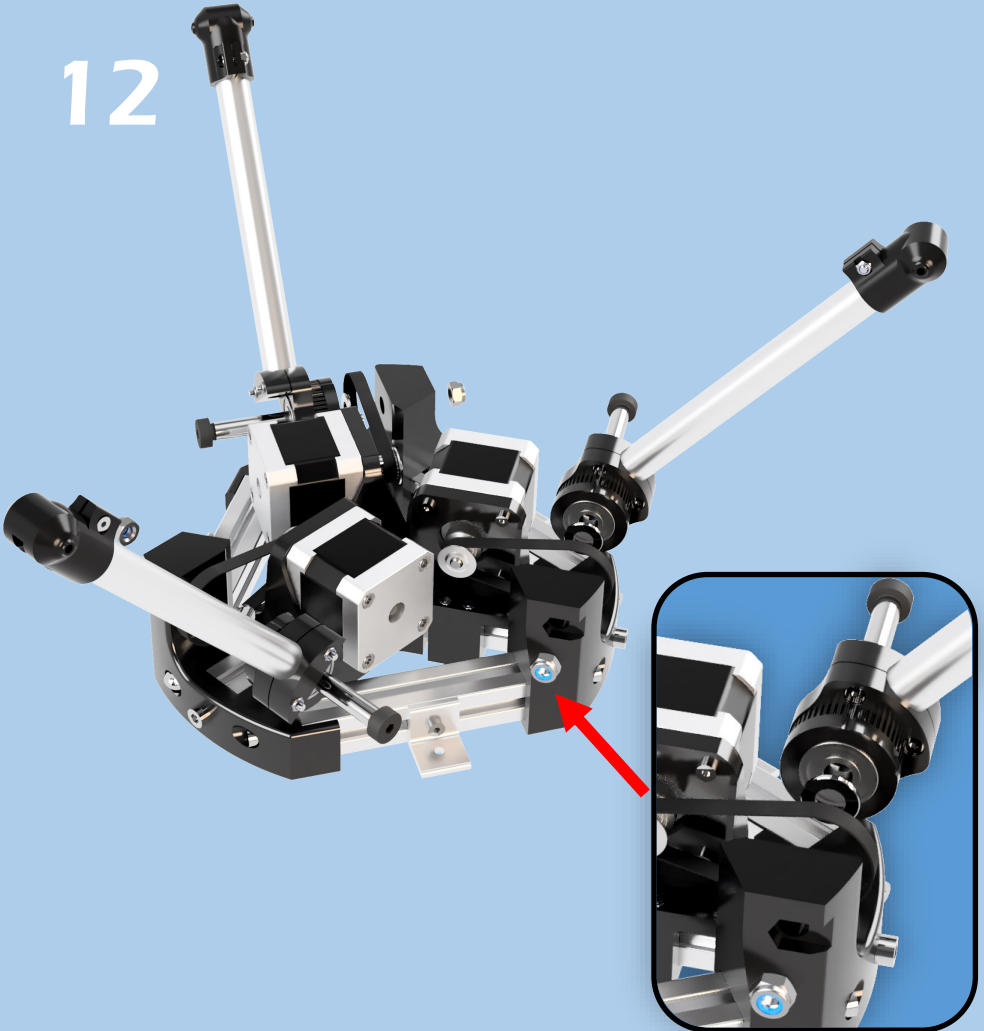

13

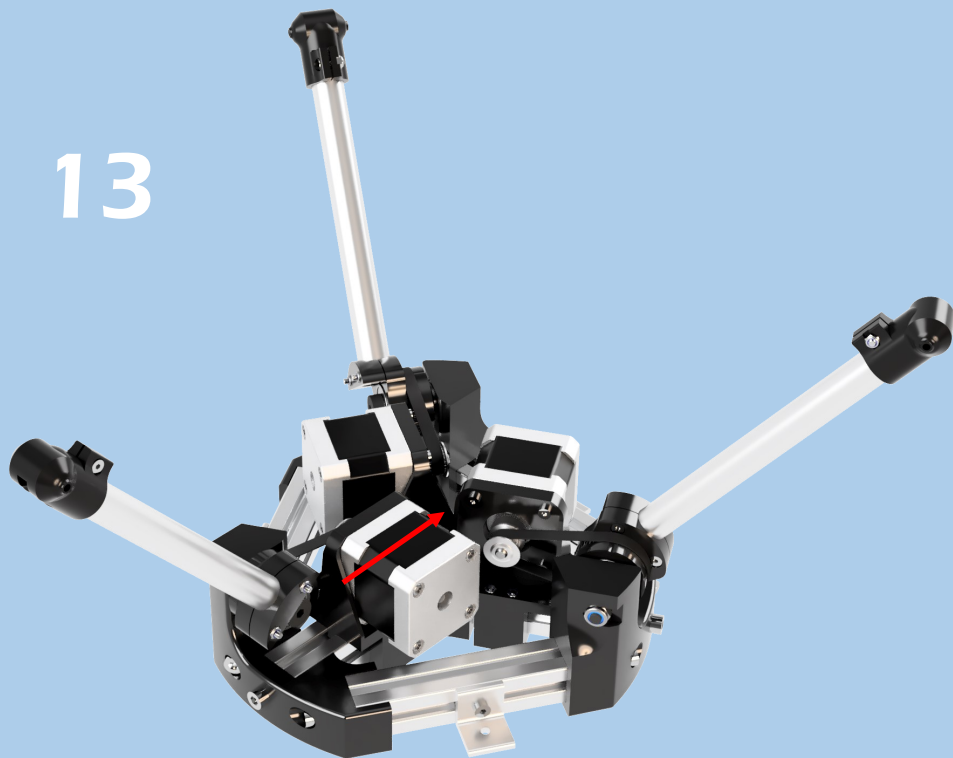

Push motors back ensuring belt tension and tighten bolts !

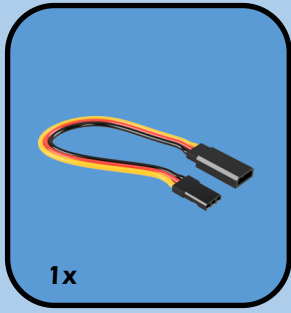

14



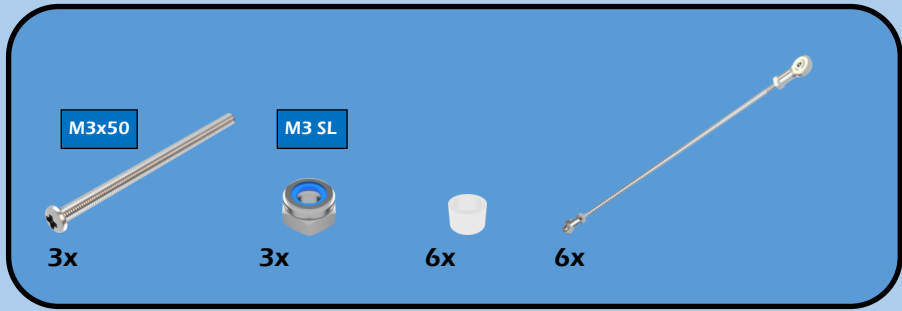

15

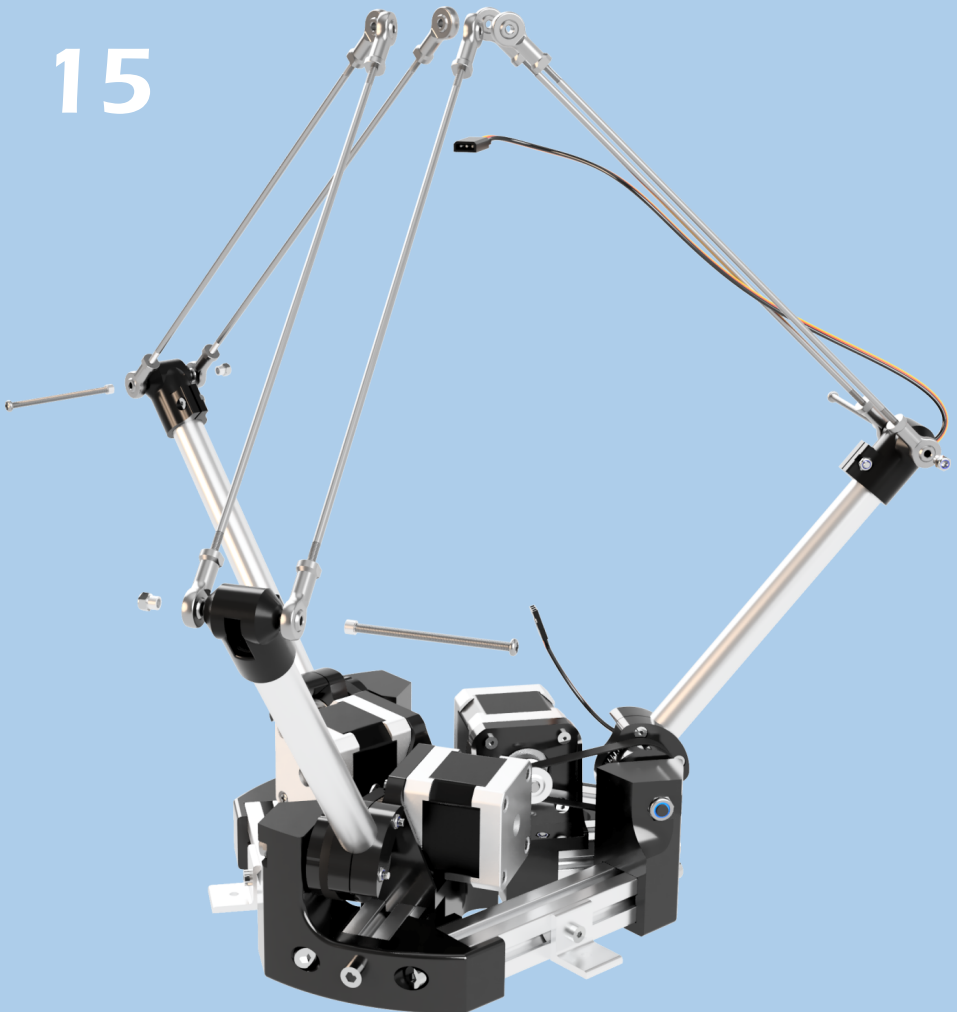

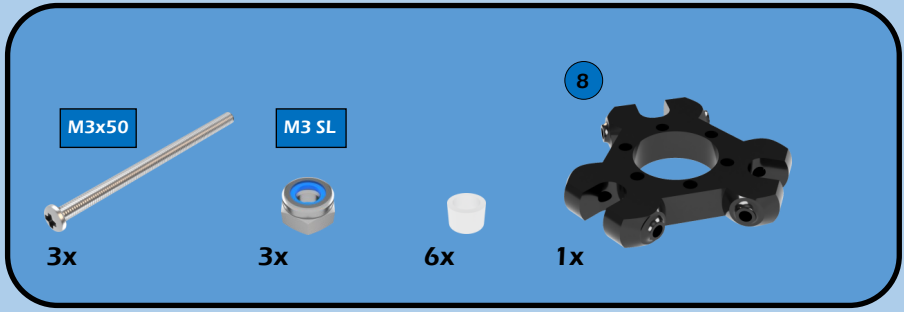

16

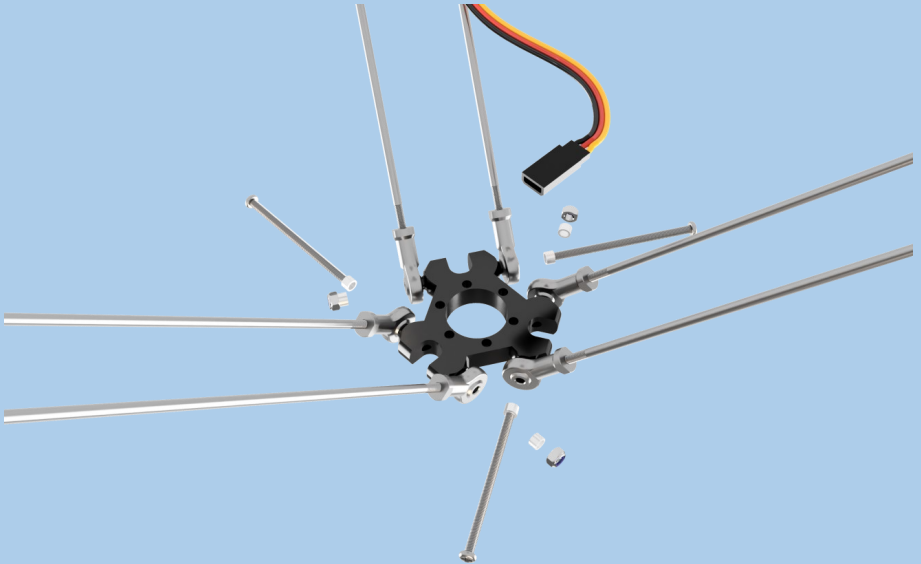

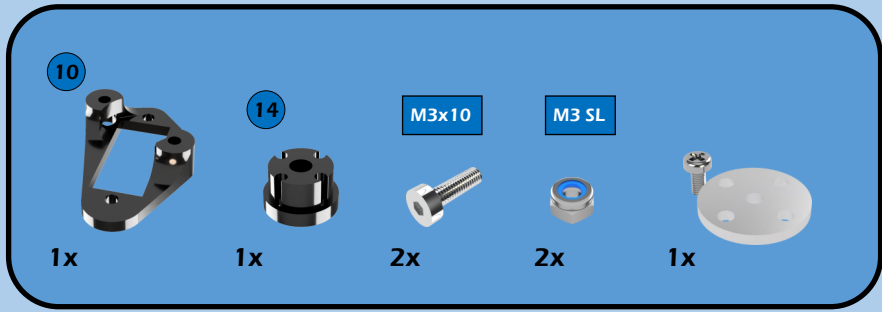

17



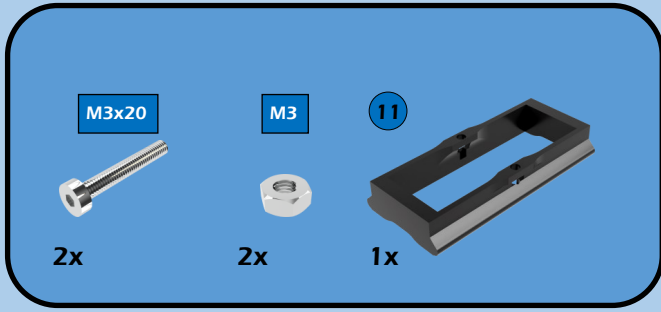

18

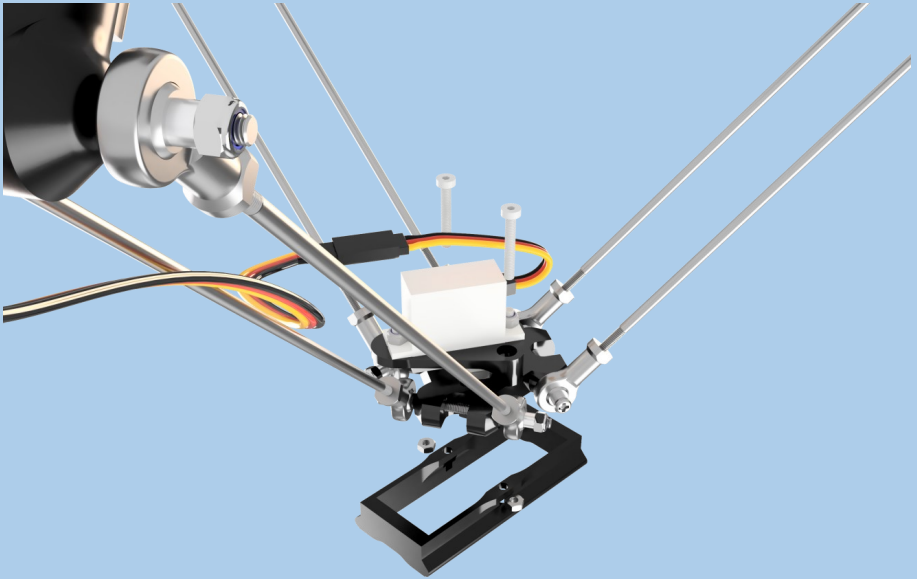

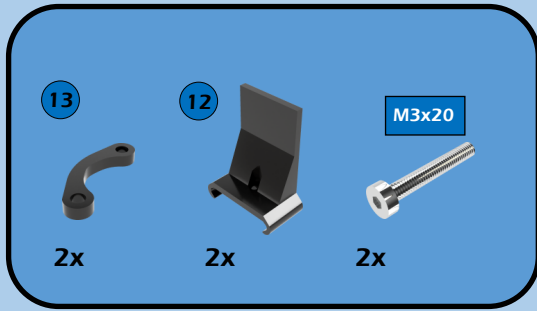

19

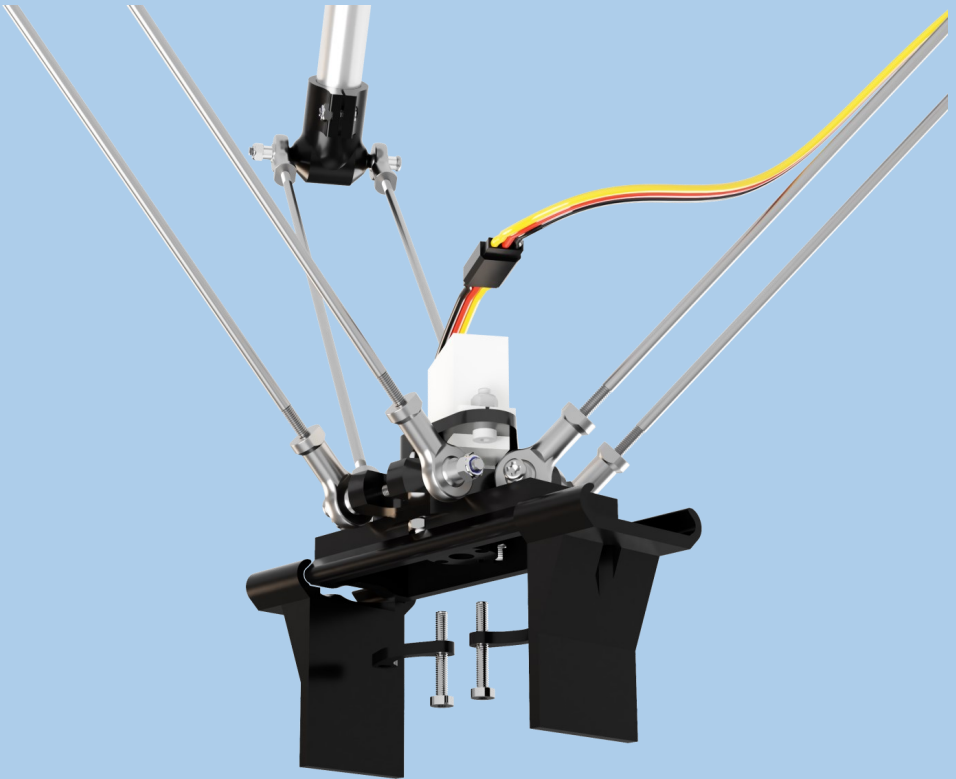

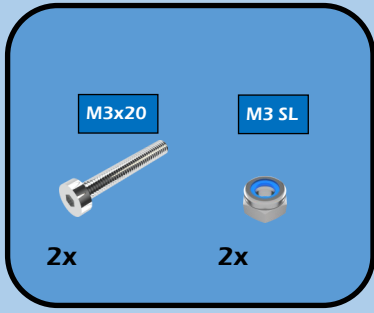

20

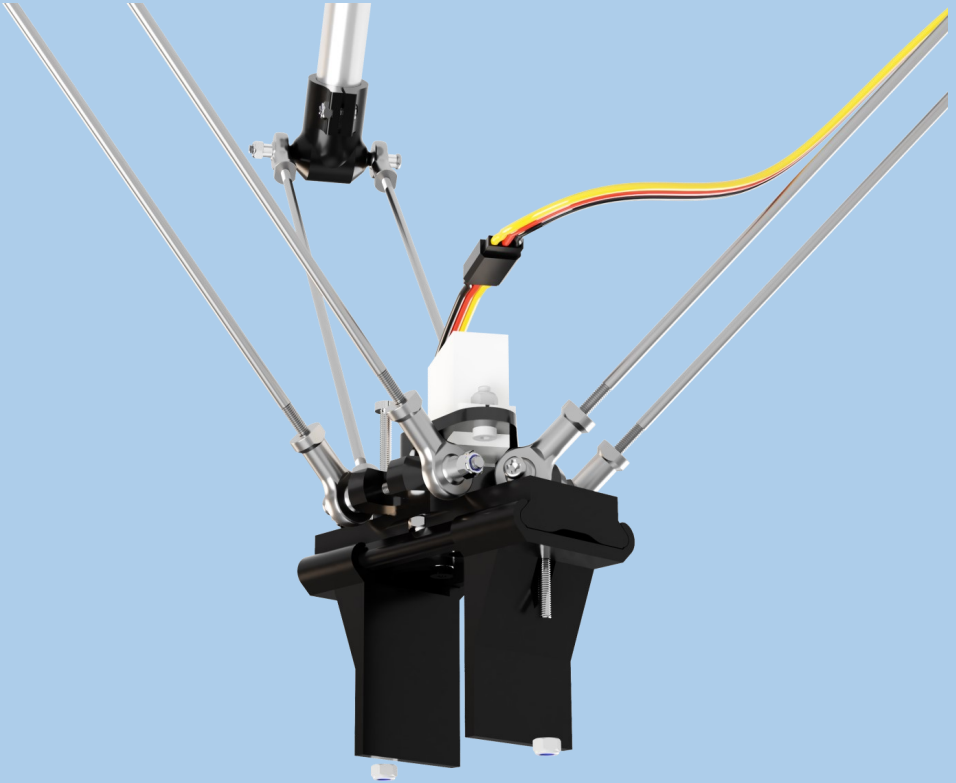

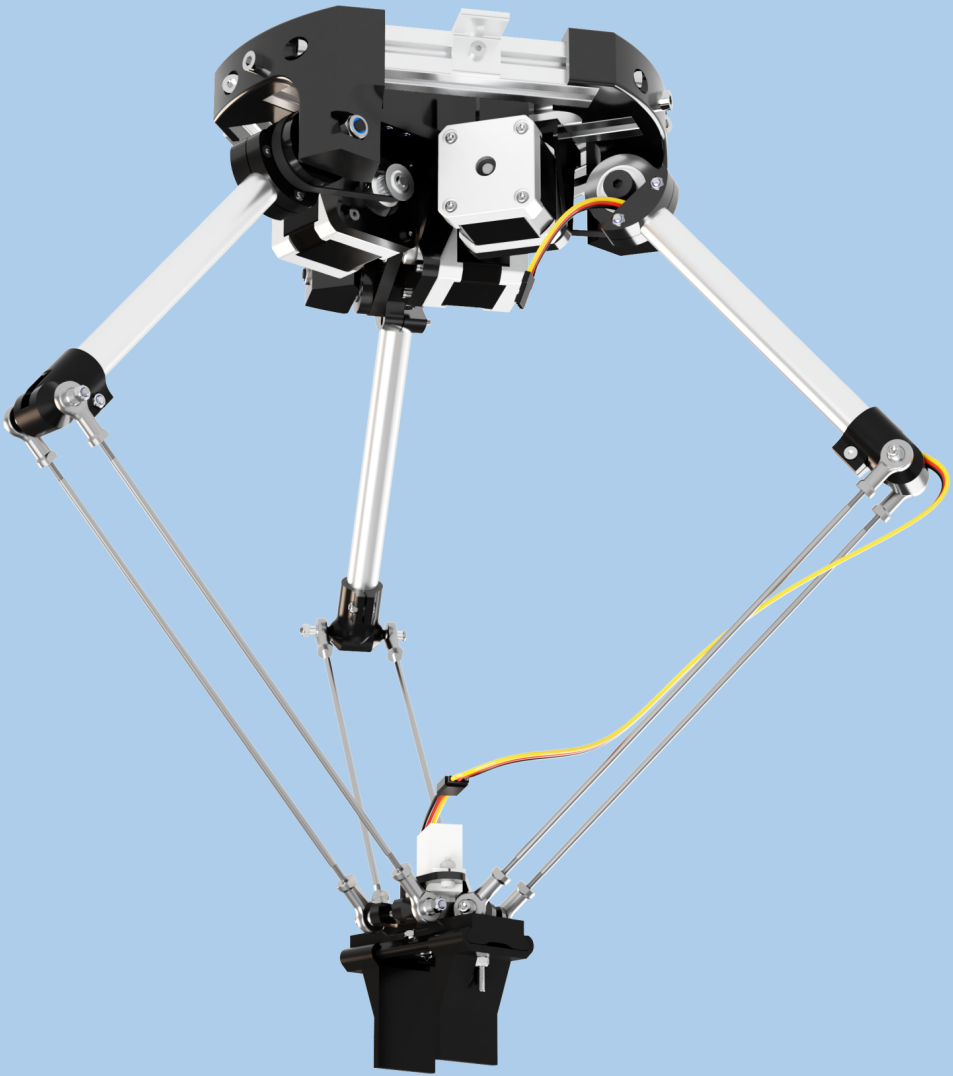

Disclaimer

1 Disclaimers and Limitation of Liability

1.1 uStepper ApS and/or ON Development IVS (or any individuals affiliated with either of the two companies) can not be held responsible for any damage inflicted upon mounting or interfacing with uStepper products This also includes damage to stepper motors (both electrical and mechanical) or any other 3rd party hardware connected to or interfacing with any uStepper products. Most stepper motor cases are made of aluminum, and care must be taken when preparing the mountings for uStepper.

1.2 uStepper ApS and/or ON Development IVS (or any individuals affiliated with either of the two companies) can not be held responsible for any damage inflicted upon assembly of the uStepper Robot Arm. This includes damage to 3D printed parts, which must be considered to be of prototyping quality compared to injection moulded parts. Care must be taken while assembling 3D printed parts, and use of excessive force may lead to damage of the parts.

1.3 By using the uStepper products (including, but not limited to, hardware and software) you acknowledge that uStepper ApS and/or ON Development IVS (or any individuals affiliated with either of the two companies) can not be held responsible for any personal injuries and/or damage to any 3rd party hardware that may occur when using the uStepper products.

1.4 To the extent permitted by law, uStepper ApS and/or ON Development IVS will not be liable for any indirect or consequential loss or damage, of any kind, (including without limitation loss of business, opportunity, data, profits) arising out of or in connection with the use of any products (including, but not limited to, hardware and software), developed, produced or sold by uStepper ApS and/or ON Development IVS (or any individuals affiliated with either of the two companies).

1.5 Nothing in these Terms and Conditions shall be construed so as to hold uStepper ApS and/or ON Development IVS liable for death or personal injury as a result of the negligence of uStepper ApS and/or ON Development IVS or that of its employees or agents.

2 Indemnity

2.1 You agree to indemnify and hold uStepper ApS and/or ON Development IVS and its employees and agents harmless from and against all liabilities, legal fees, damages, losses, costs and other expenses in relation to any claims or actions brought against uStepper ApS and/or ON Development IVS arising out of any breach by you of these Terms and Conditions or other liabilities arising out of your use of this Website.

2.2 You agree to indemnify and hold uStepper ApS and/or ON Development IVS and its employees and agents harmless from and against all liabilities, legal fees, damages, losses, costs and other expenses in relation to any claims or actions brought against uStepper ApS and/or ON Development IVS arising out of any breach by you of these Terms and Conditions or other liabilities arising out of your use of products(including, but not limited to, hardware and software) developed, produced or sold by uStepper ApS and/or ON Development IVS (or any individuals affiliated with either of the two companies).

3 Severance

If any of these Terms and Conditions should be determined to be invalid, illegal or unenforceable for any reason by any court of competent jurisdiction then such Term or Condition shall be severed and the remaining Terms and Conditions shall survive and remain in full force and effect and continue to be binding and enforceable.

